

## 11. Bug Robot

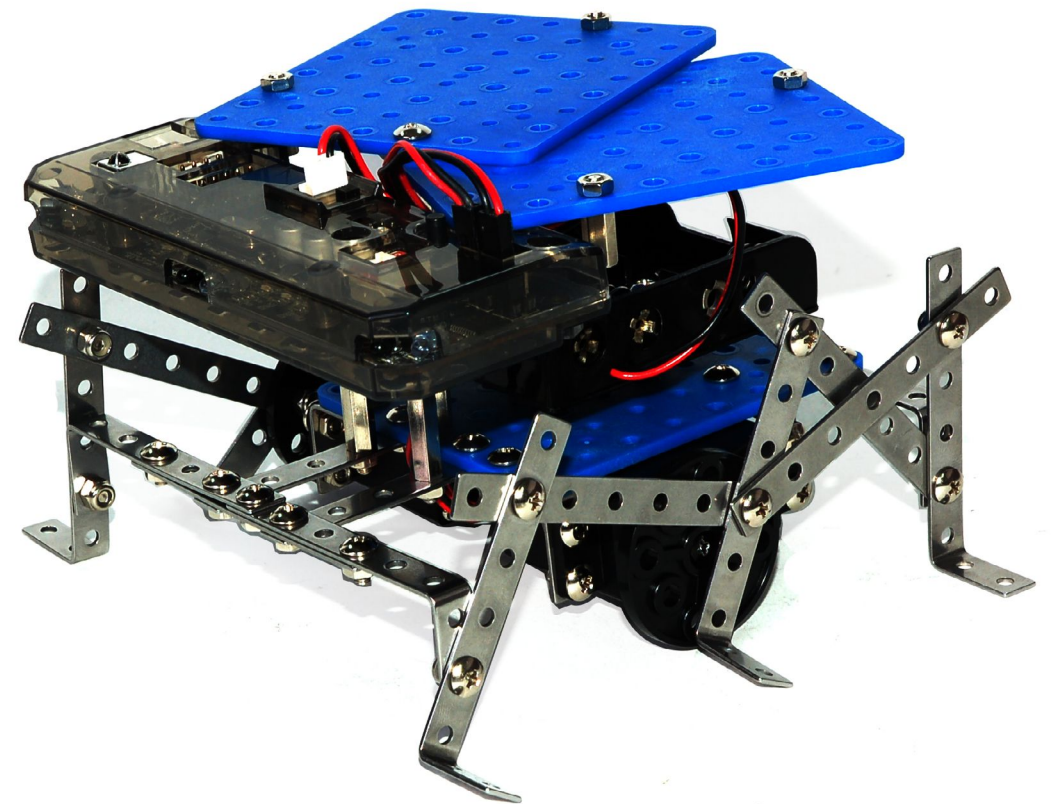

# Introduction and how it works



This robot has 2 DC motors and 6 legs that can be moved.

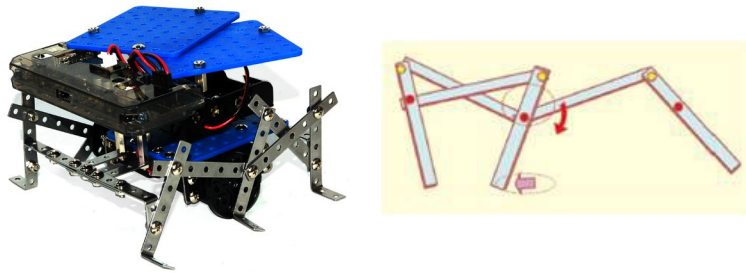

This robot can change rotational motion to reciprocating motion and vice versa.

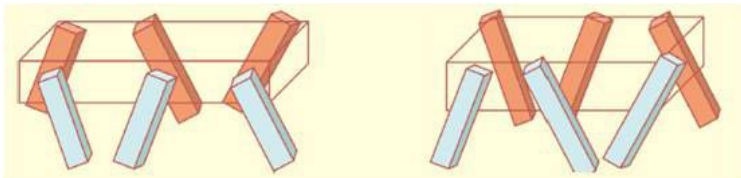

Many devices or robots use the function that can change rotational motion to reciprocating motion and vice versa.



1

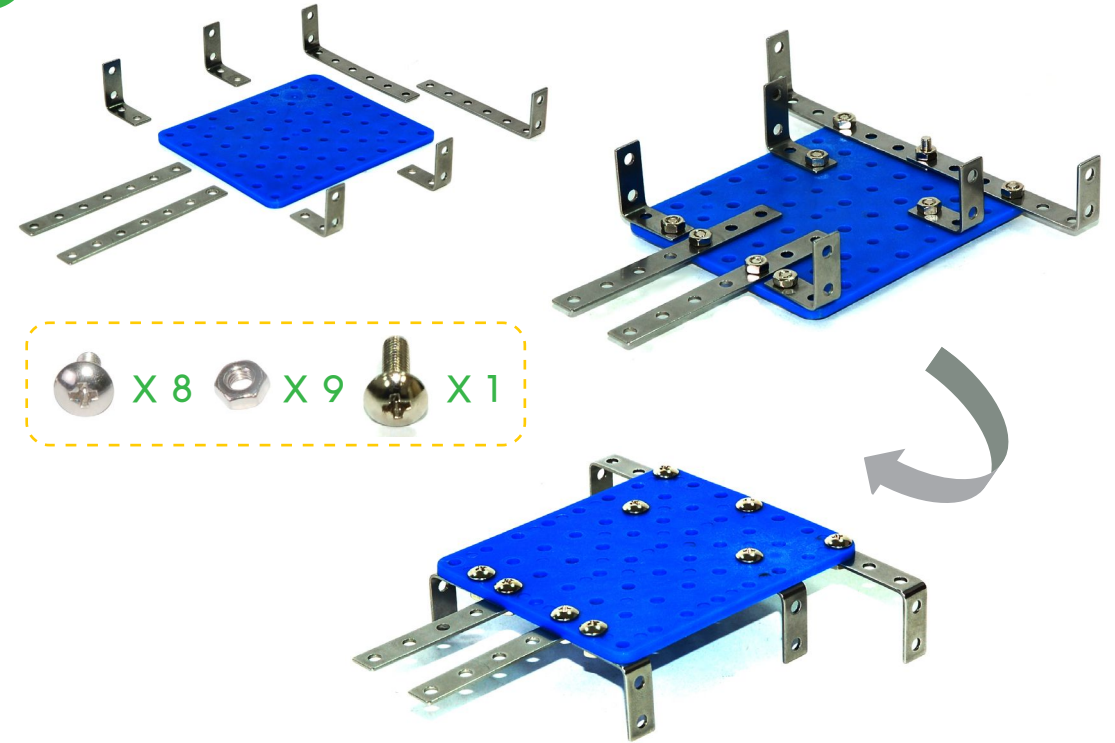

2

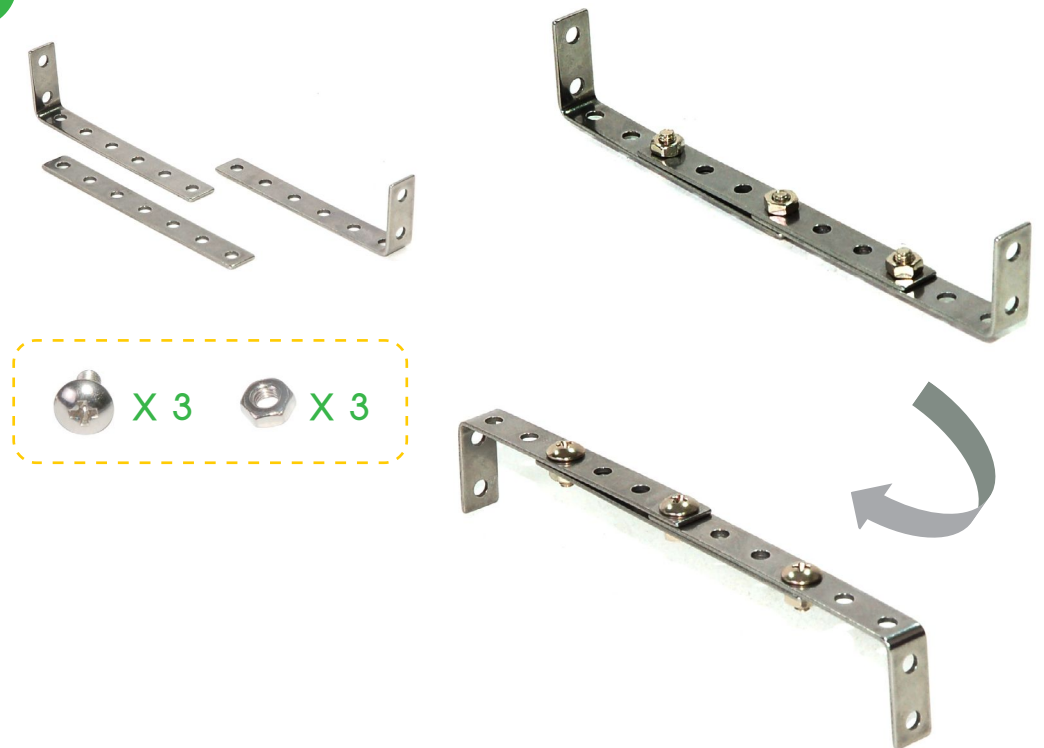

3

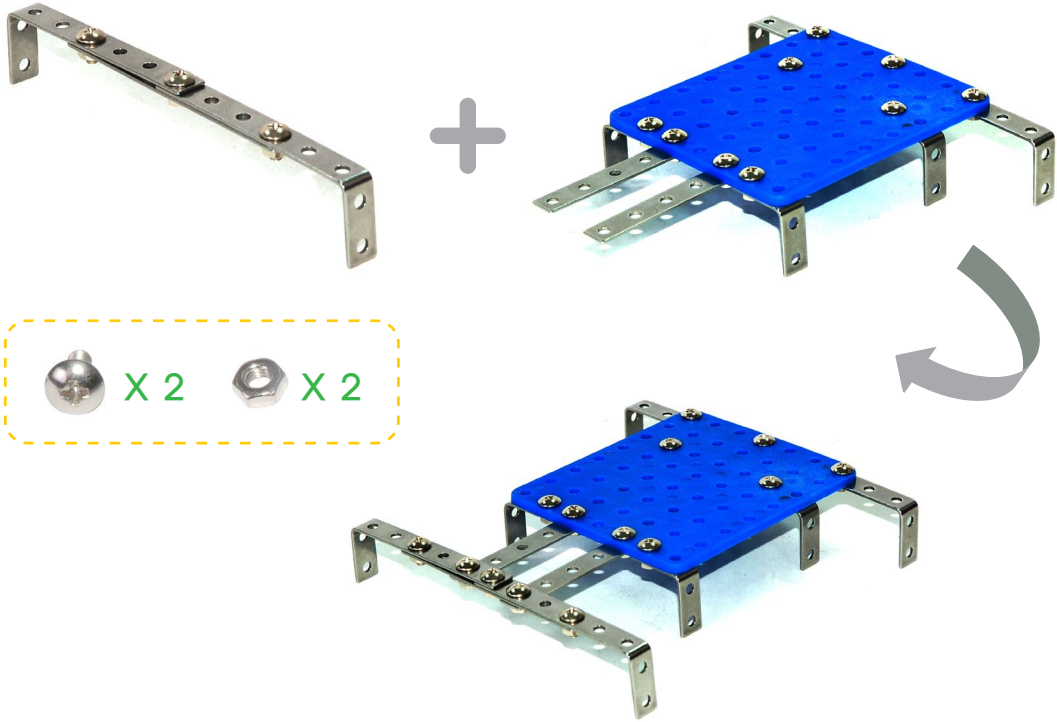

5

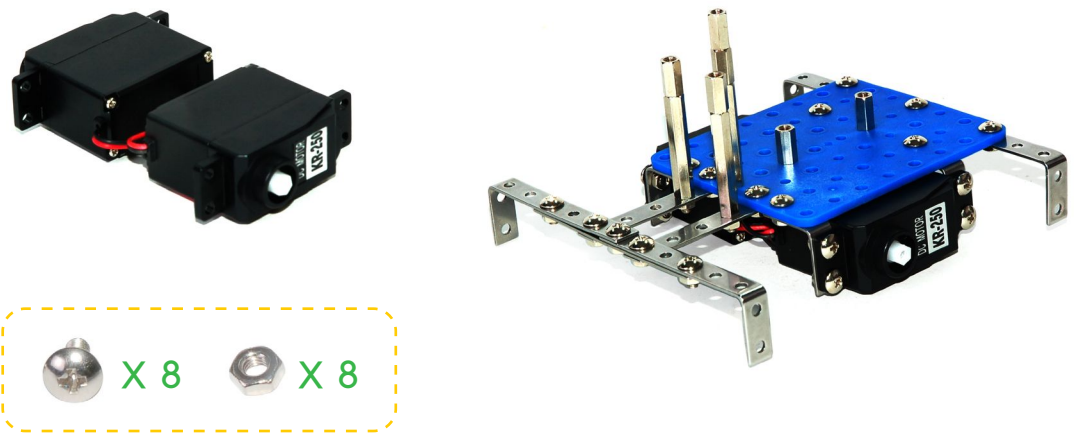

4

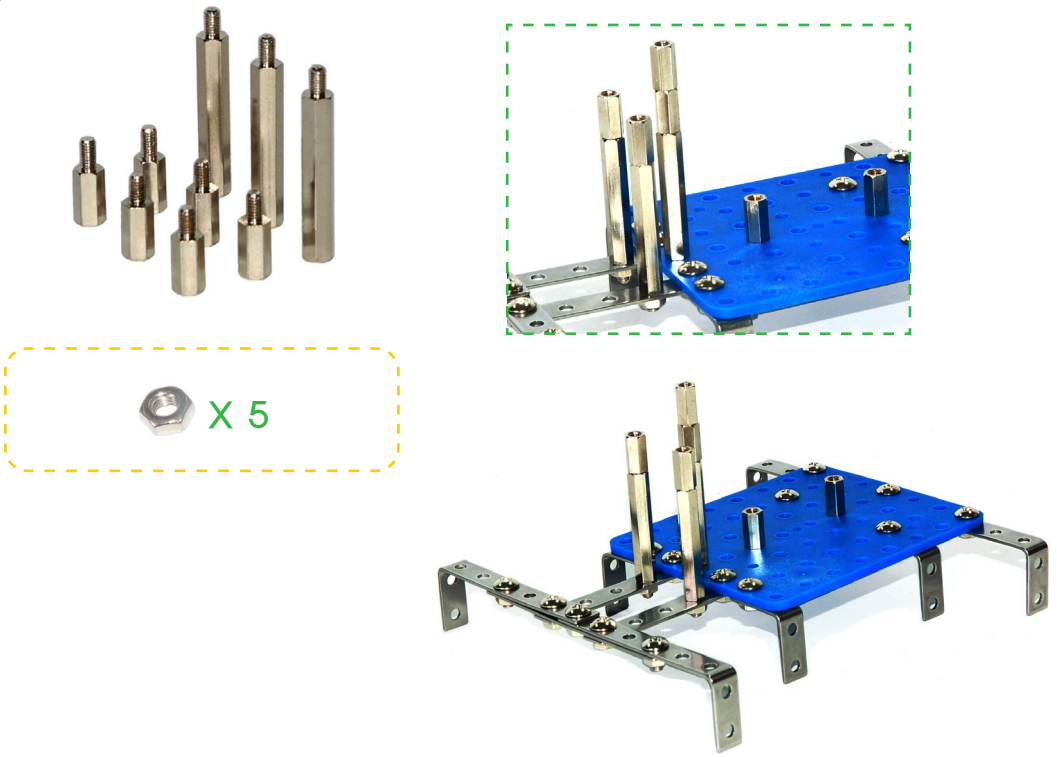

6

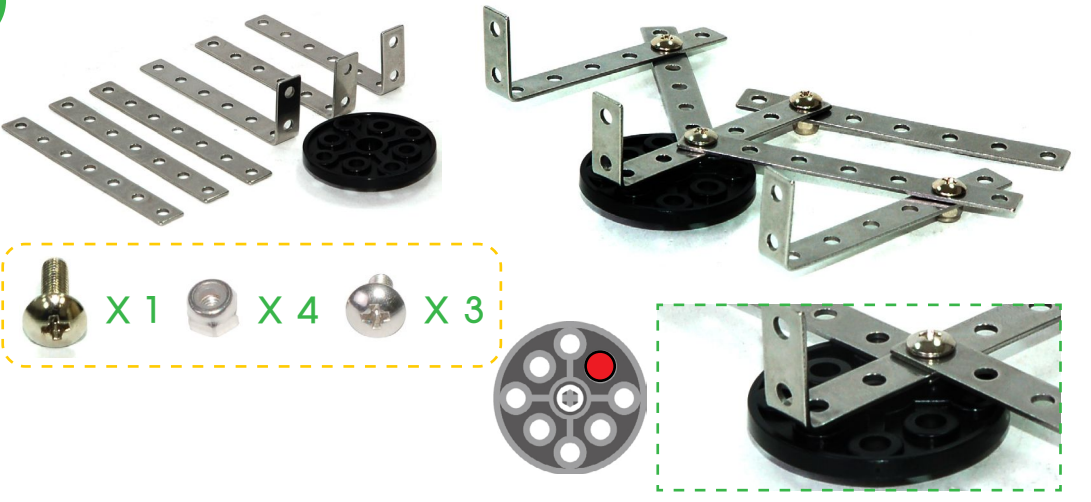

7

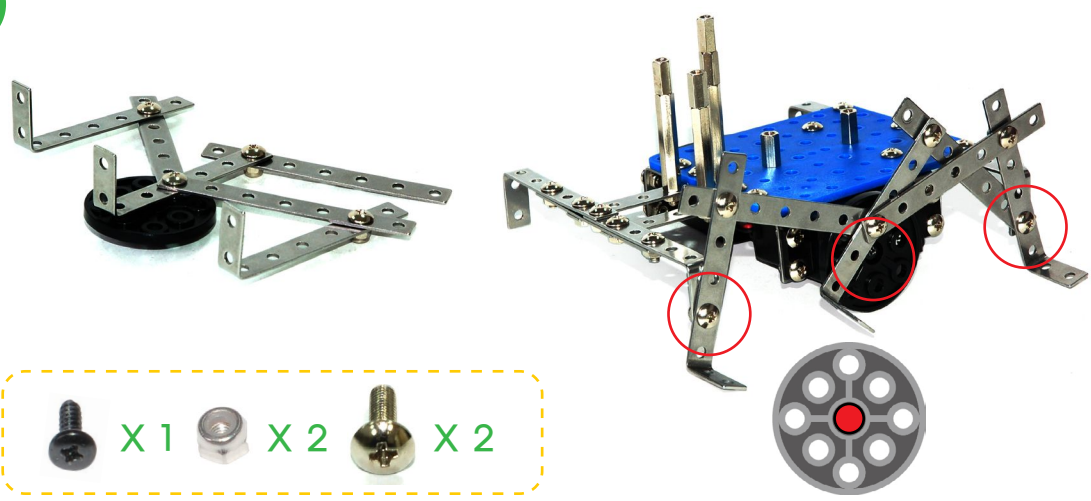

8



X1 X4 X3



9

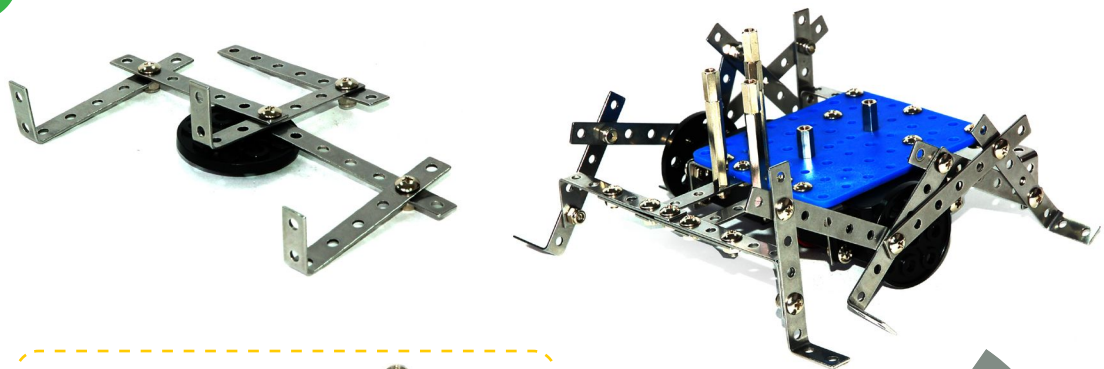

X1 X2 X2

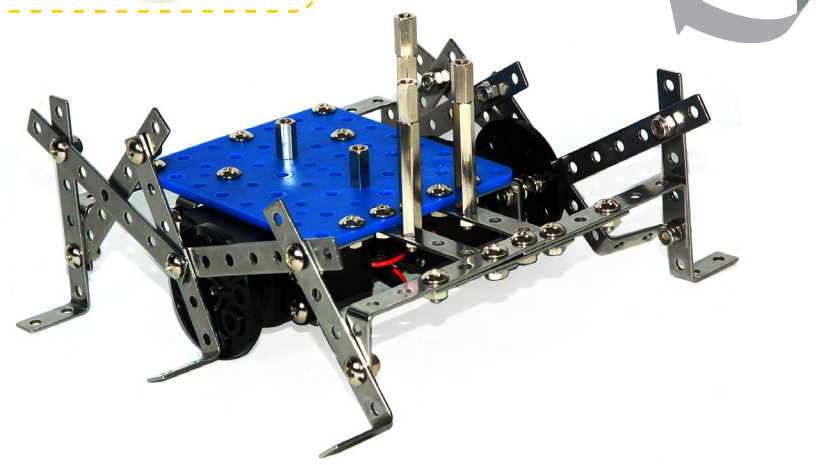

10

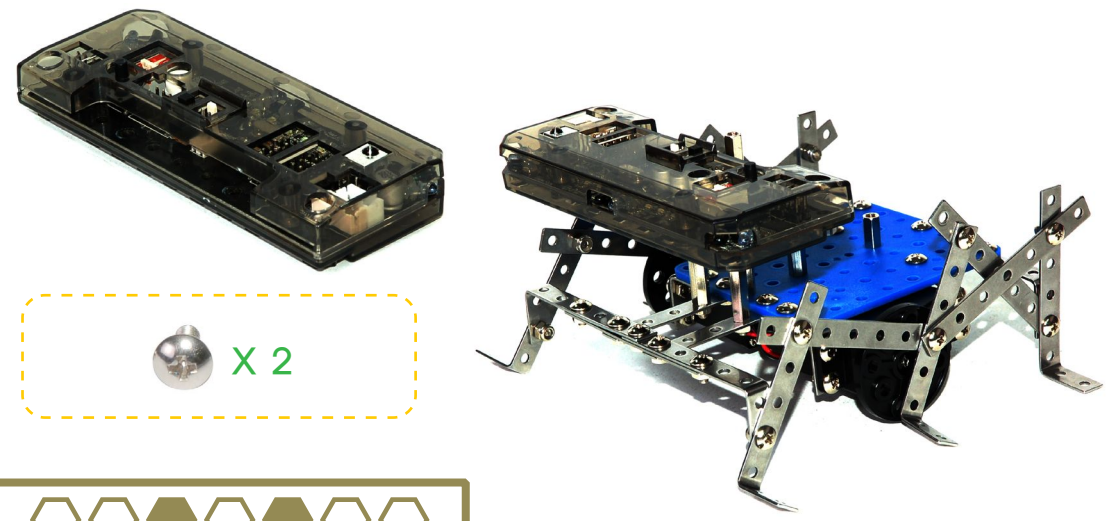

X2

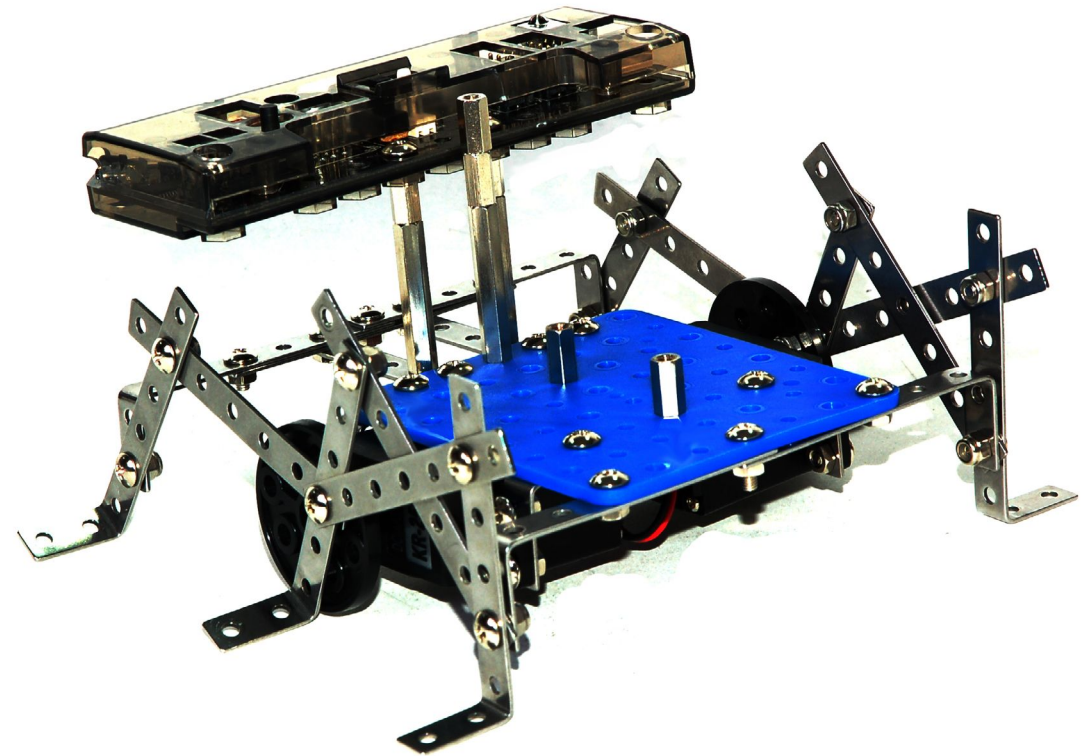

11

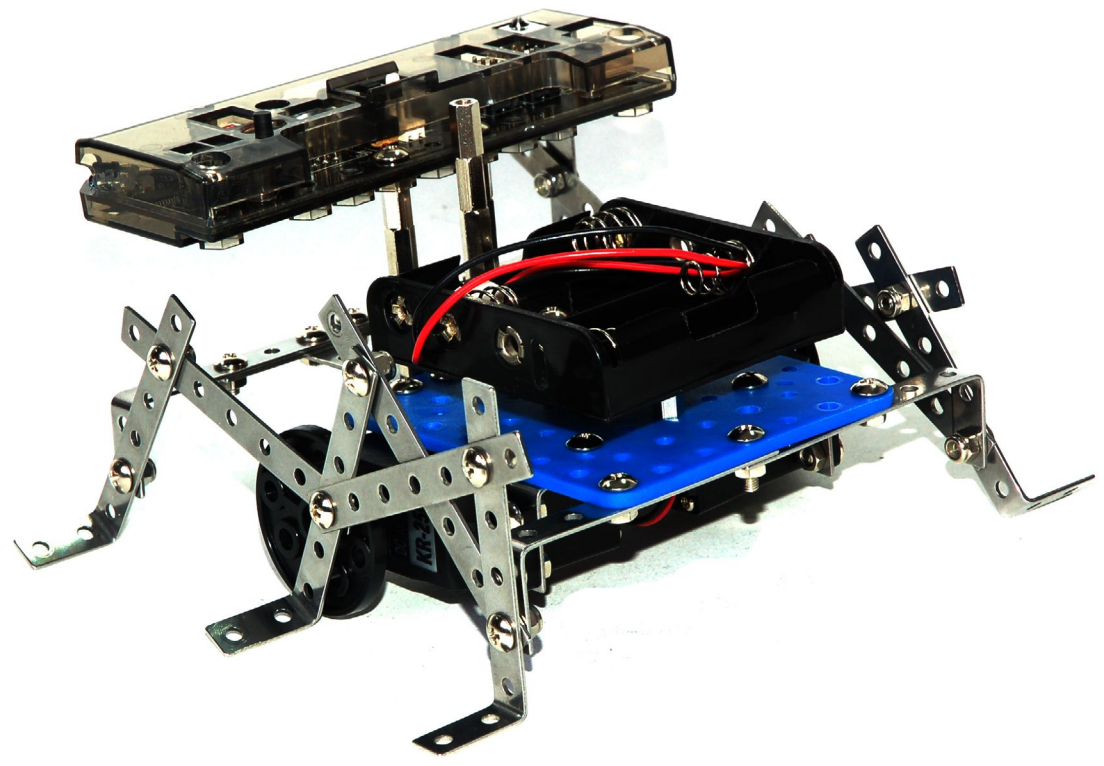
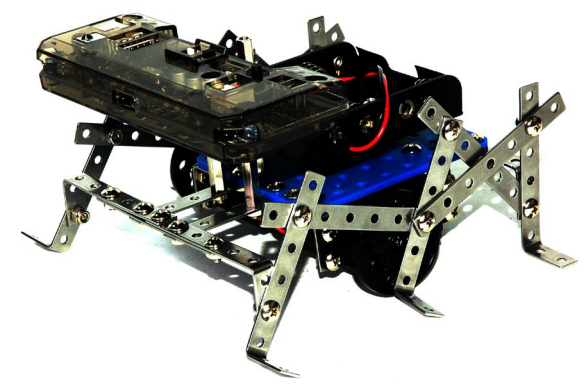
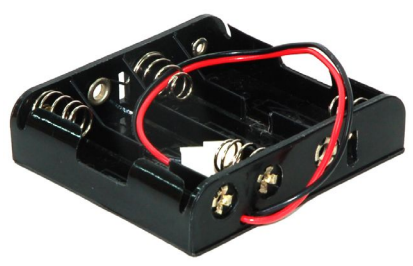

12

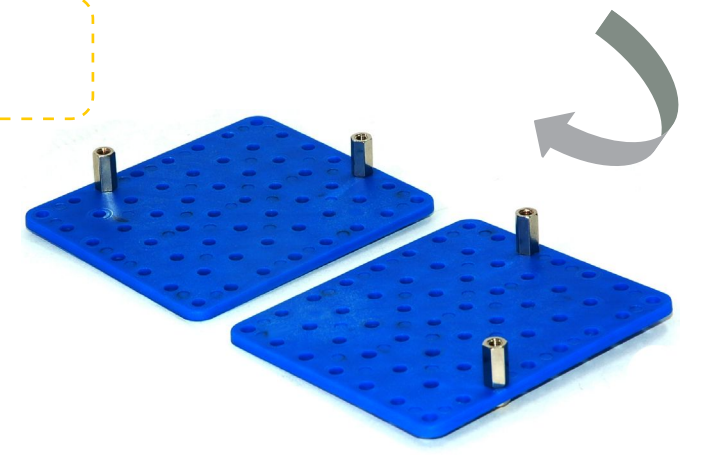
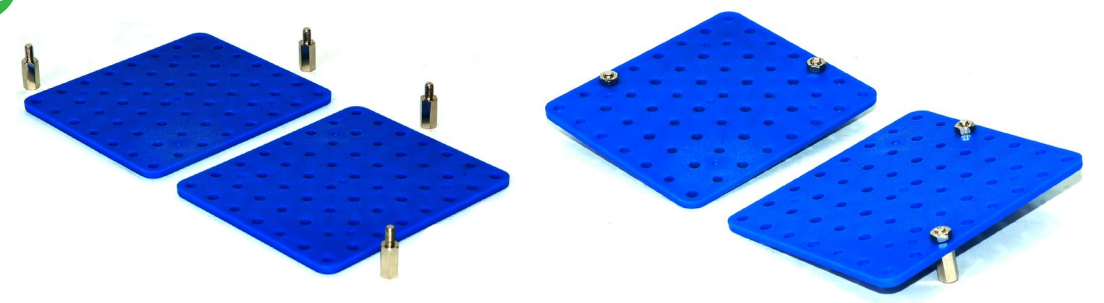

13

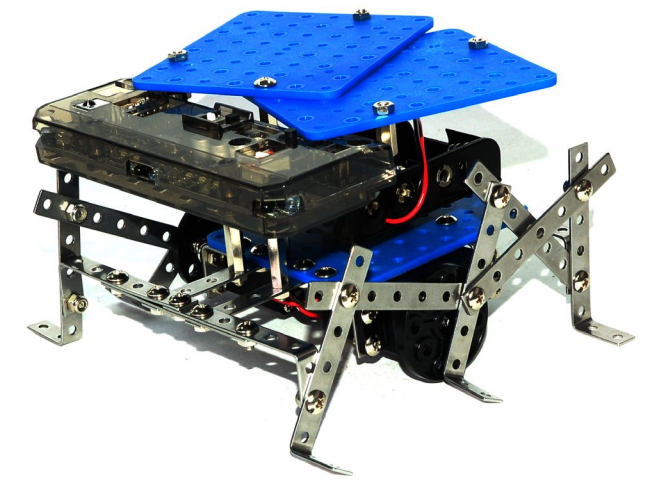

completion

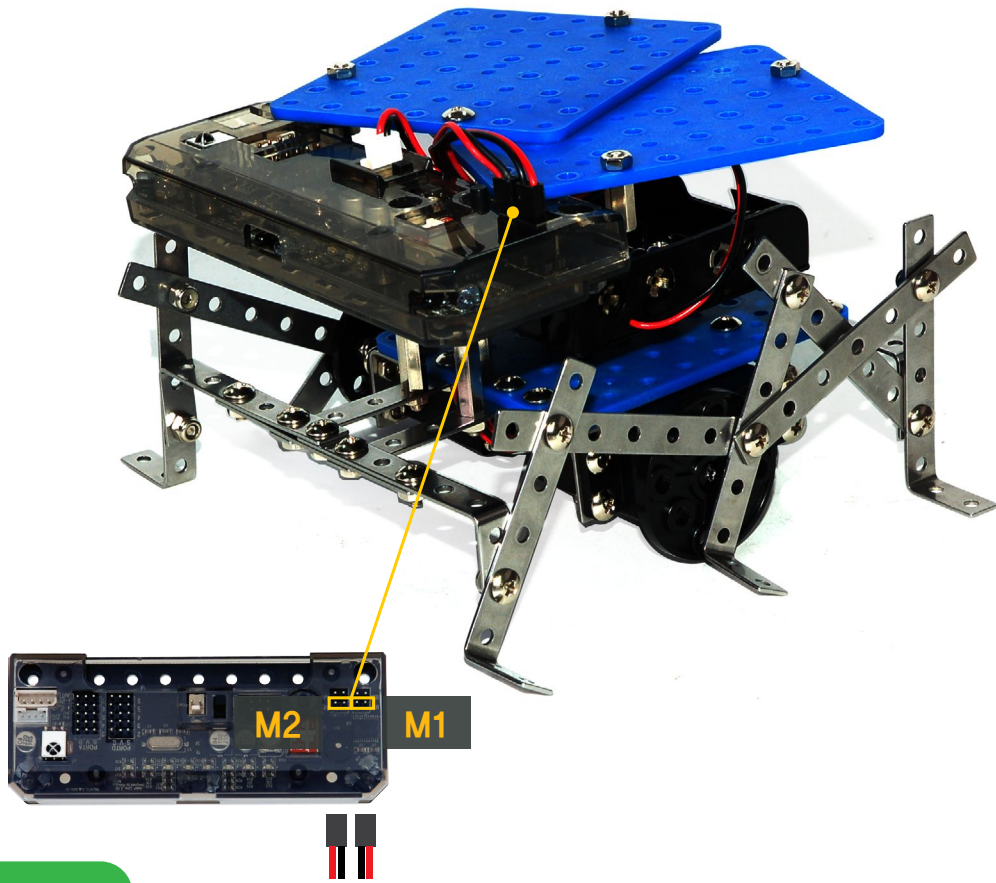

Back view

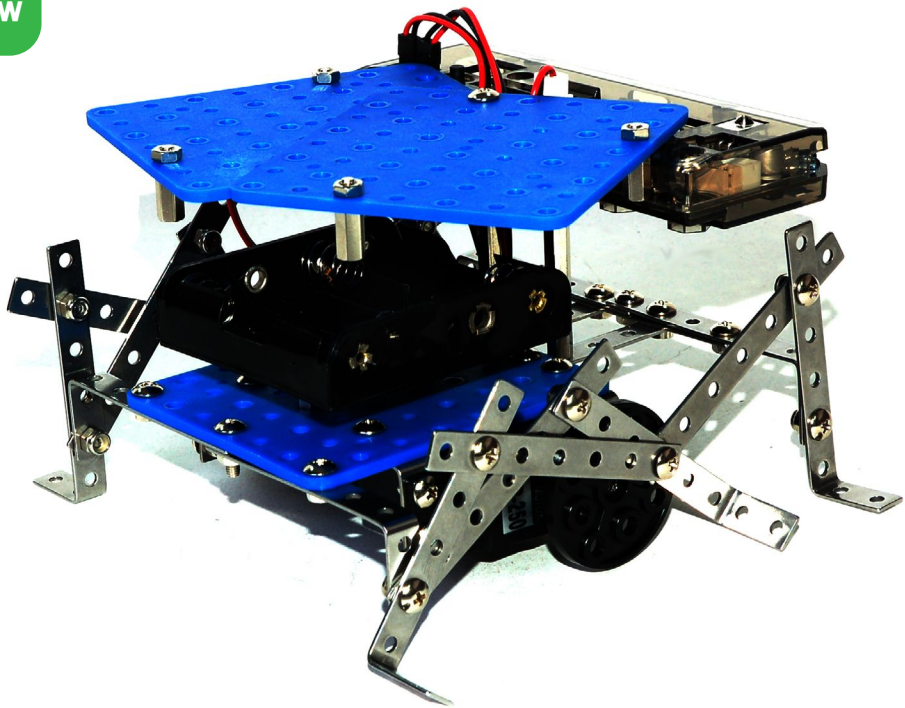

Acting Module



Bug Robot uses program mode 11 to operate.

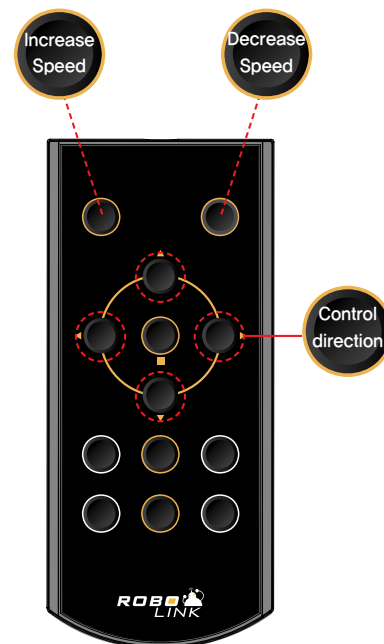
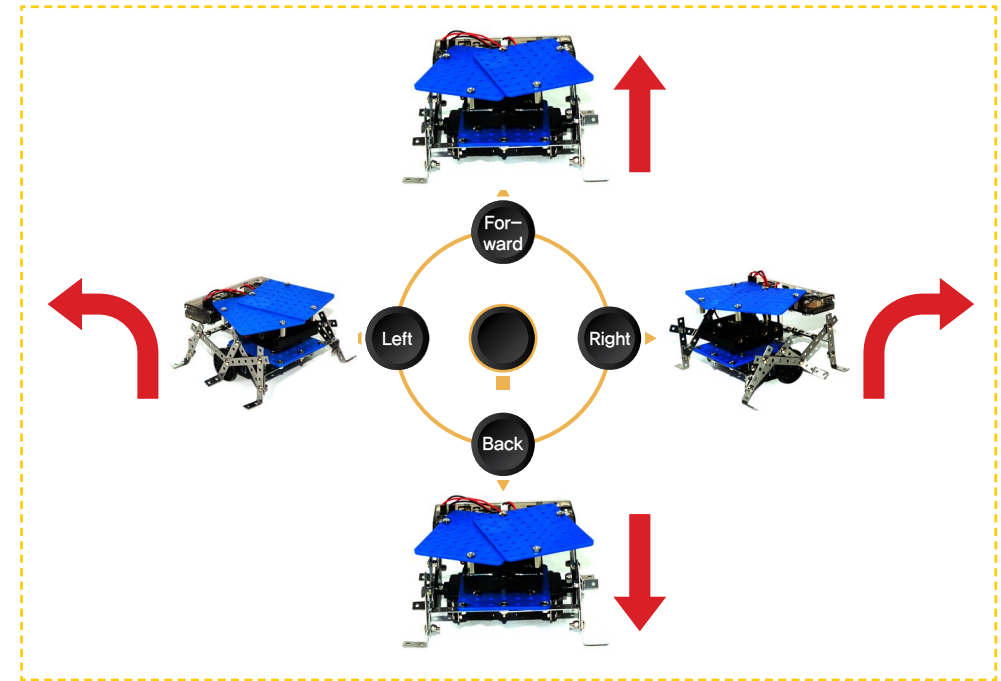

When the speed increases, more LEDs turn on, and vice-versa.

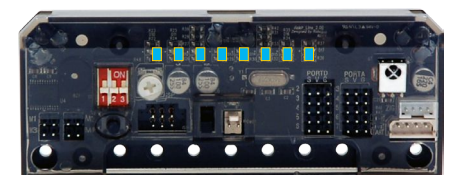
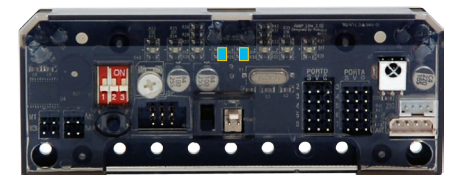

## Play the Game!



1. 1:1 is okay, but 2:2 is more interesting.
2. Make a circle with a diameter of 60cm using black tape.  
(It can also be a hexagon)
3. Place the robots at center of the circle, and run the program.
4. After you hear a starting signal, control your robot with the IR remote controller.  
The purpose of this game is to push other robots out from the circle.
5. If a robot's two motors are out of the circle, then that robot loses the game.
6. 1 minute is good enough for game time.
7. It is more interesting to play on a circular chair or table.

