

9. Motion Capturing Robot

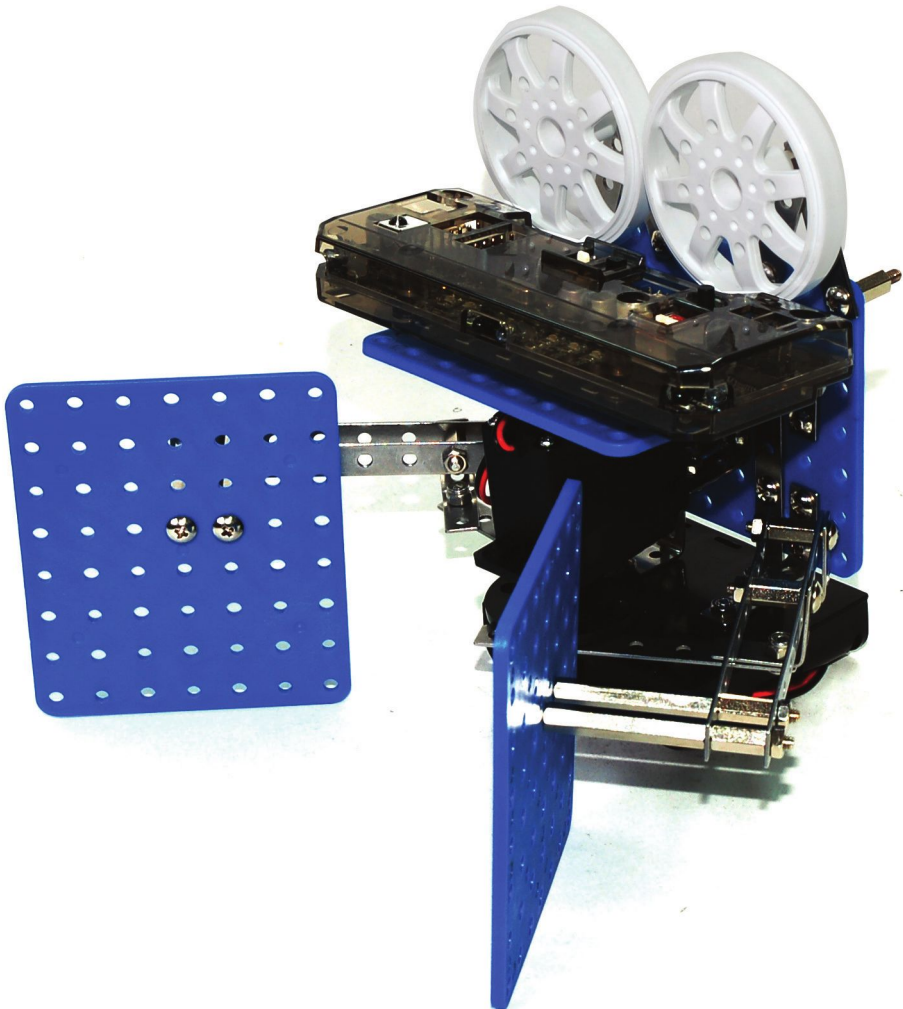

Introduction and how it works



When this robot detects an object or a hand, its hands will close to catch it. However, this robot does not close its hands all the time.

This robot's program has a function that causes it to move randomly. Some games or entertainment machines use this function.



1

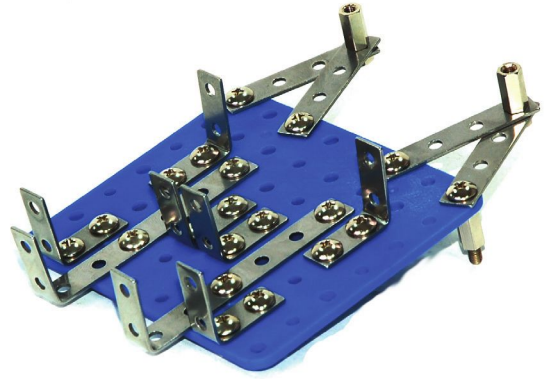
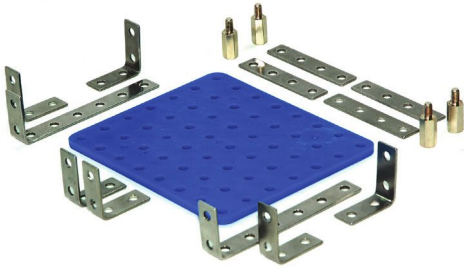

 X 20  X 20

2

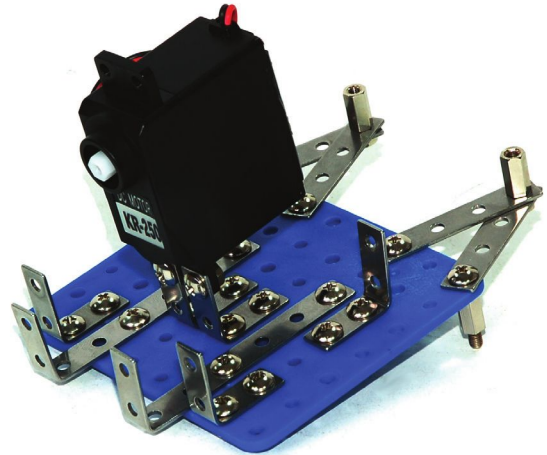

 X 2  X 2

3

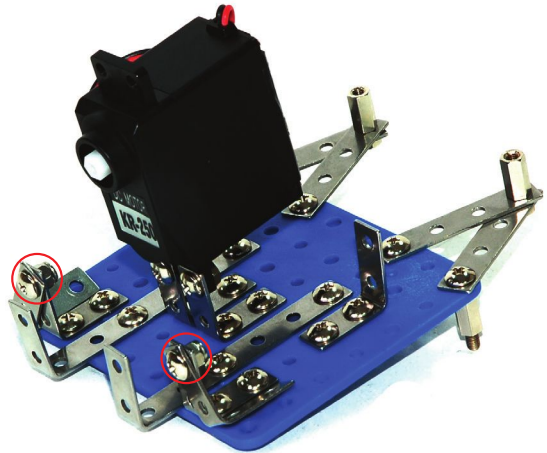

 X 2  X 2

4



5

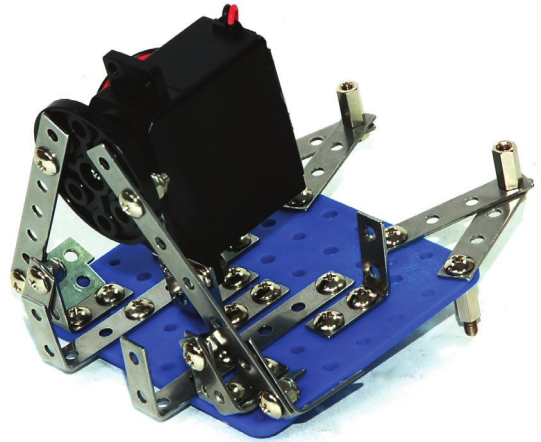

6

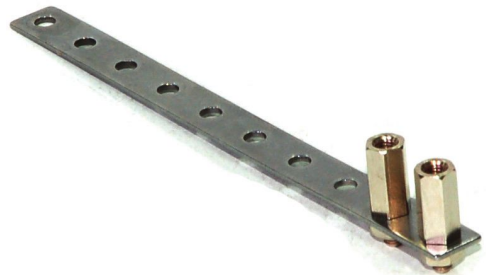

7



X 2

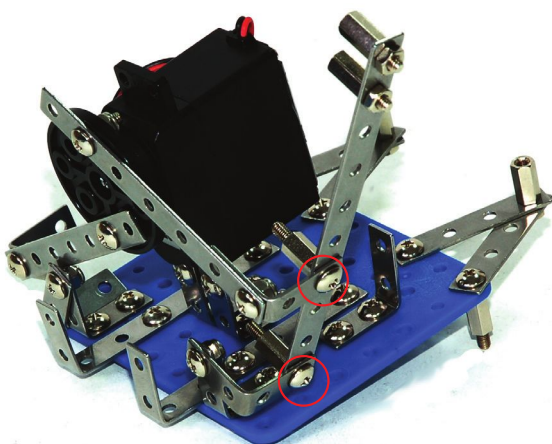

8



X 2

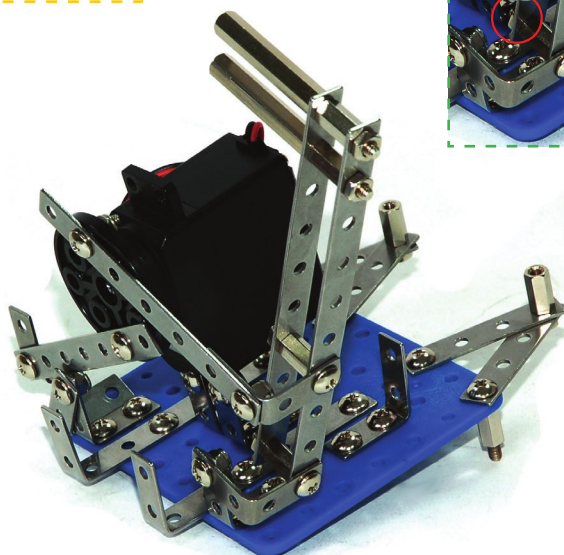
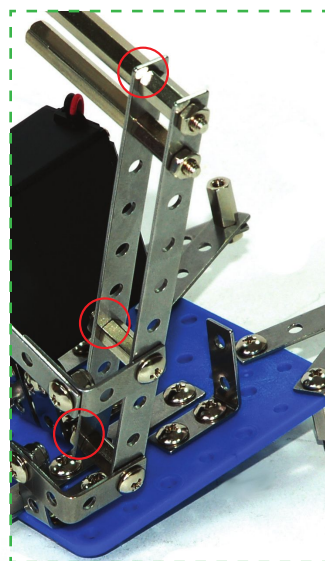

9

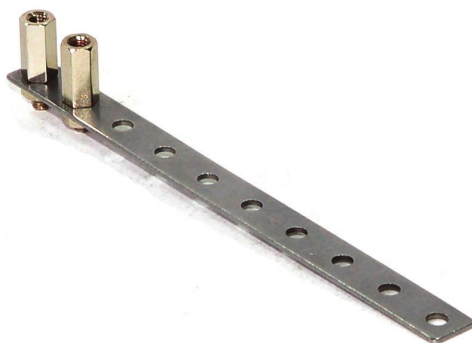
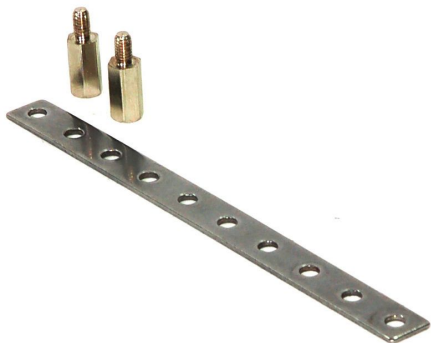

 X 2

10

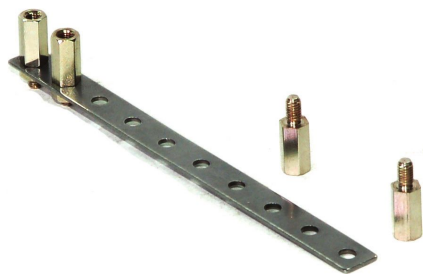

 X 2

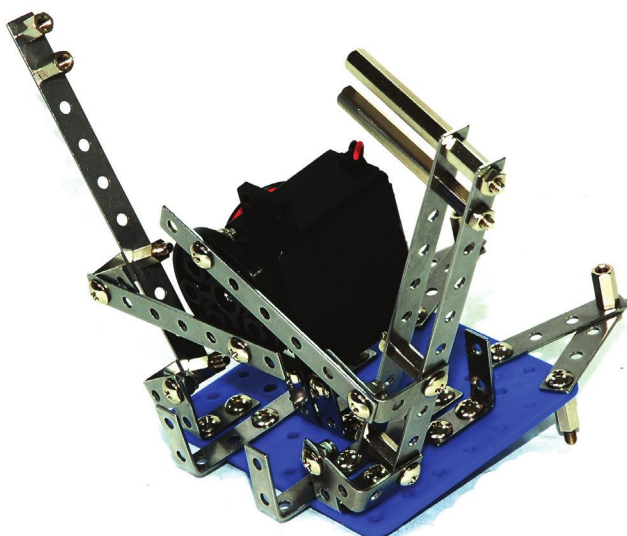
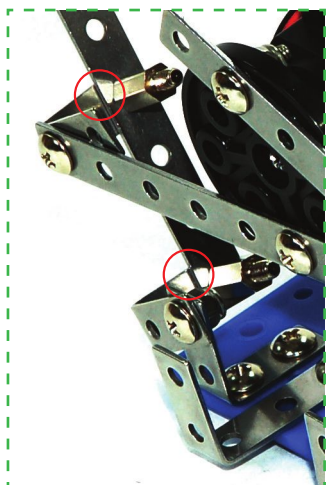

11

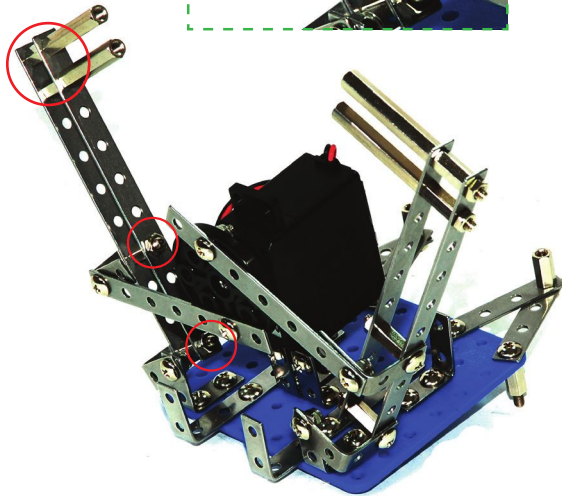
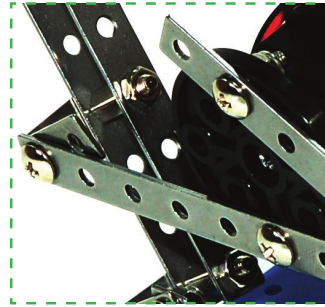
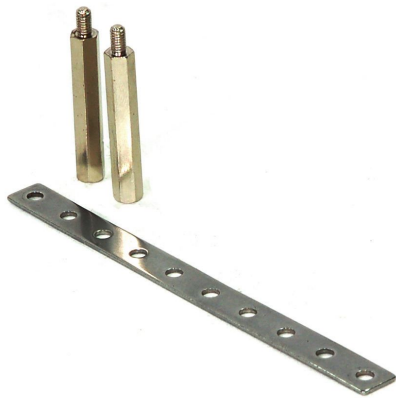

12

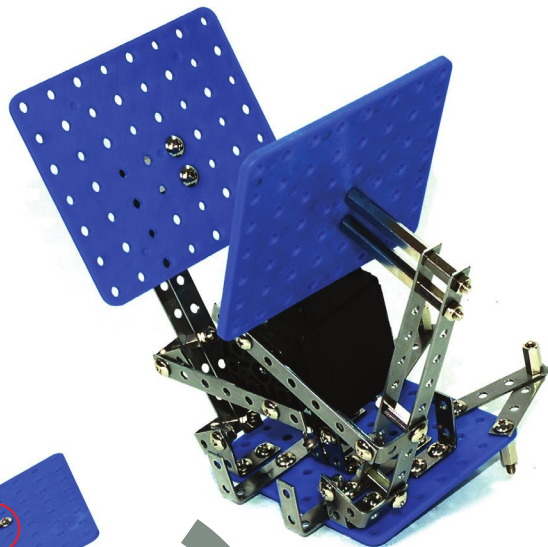
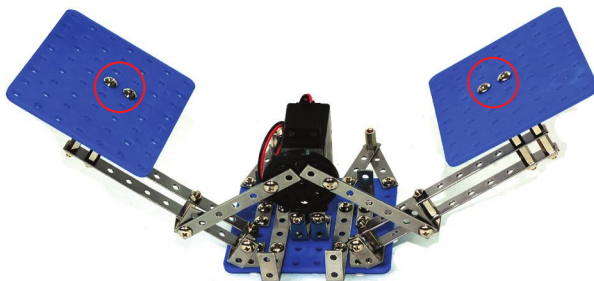
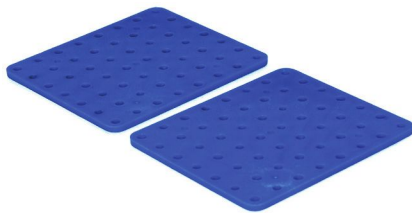

13

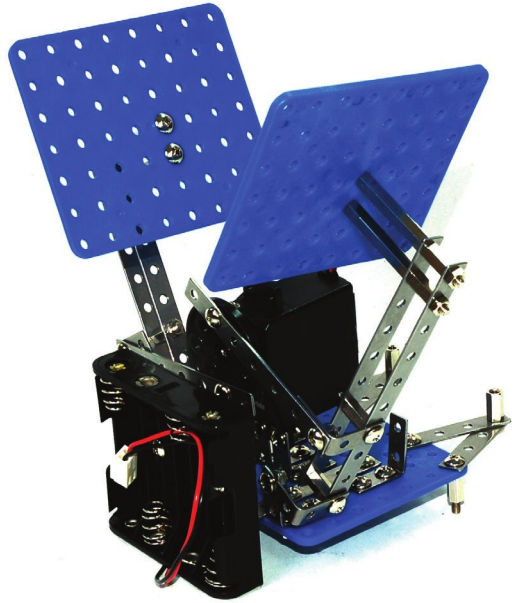
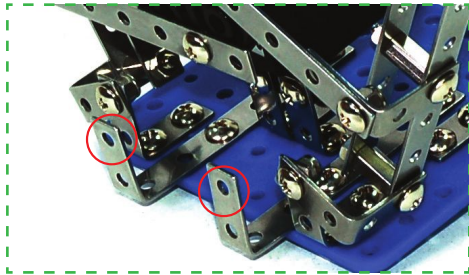
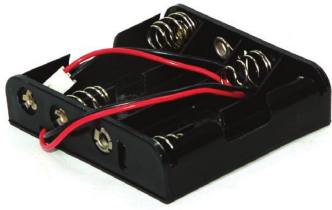

14

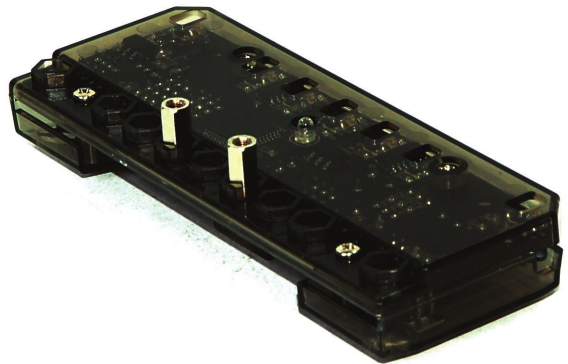

15

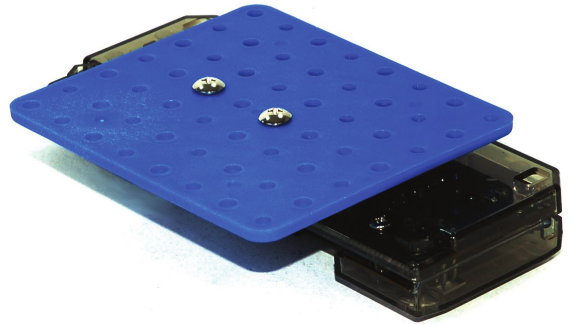

16

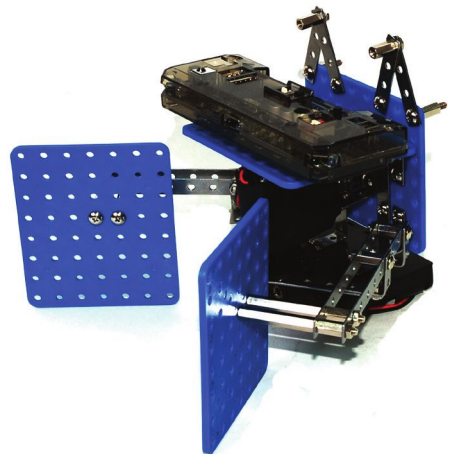
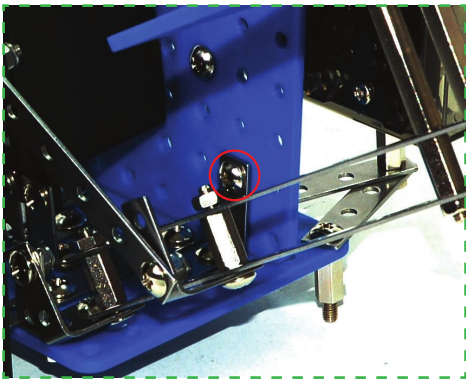
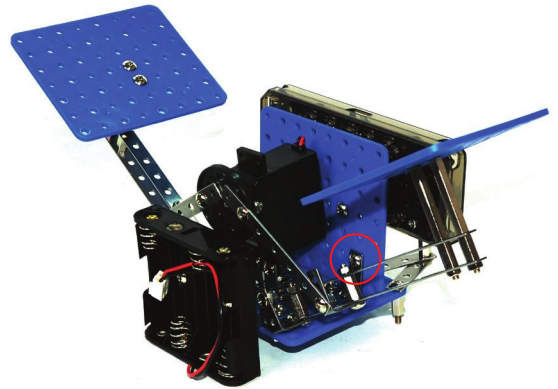
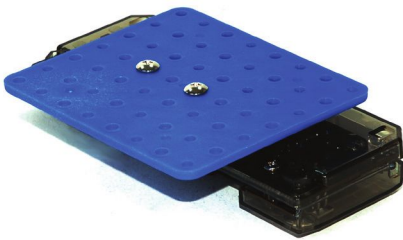

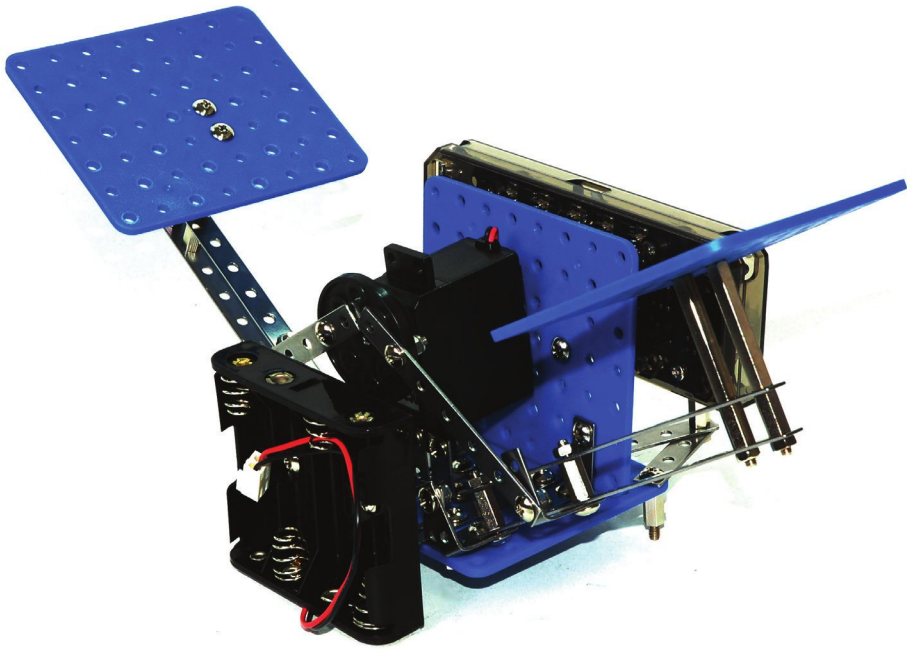
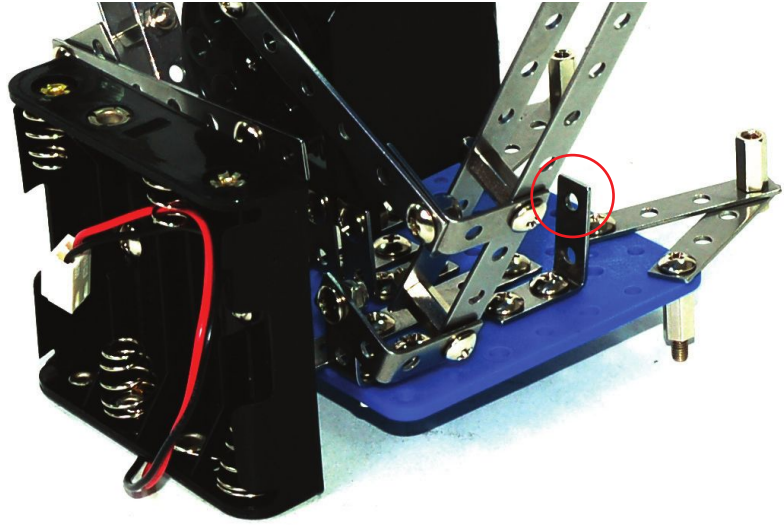

17



X 2

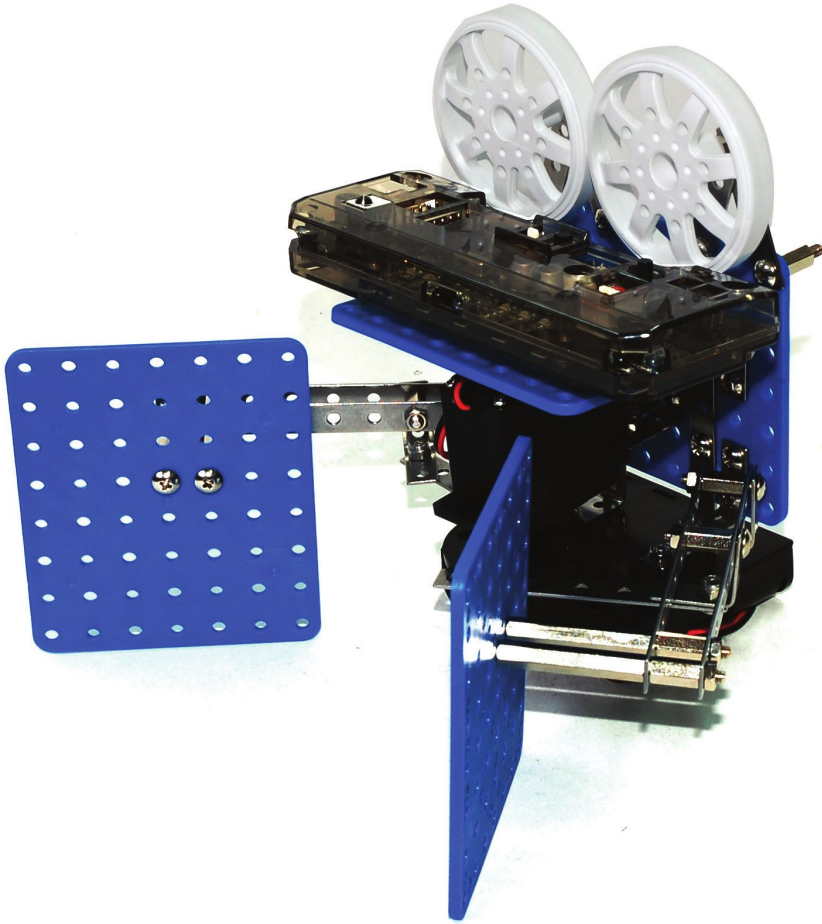
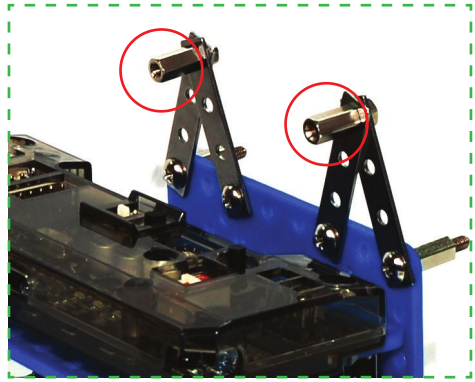

completion

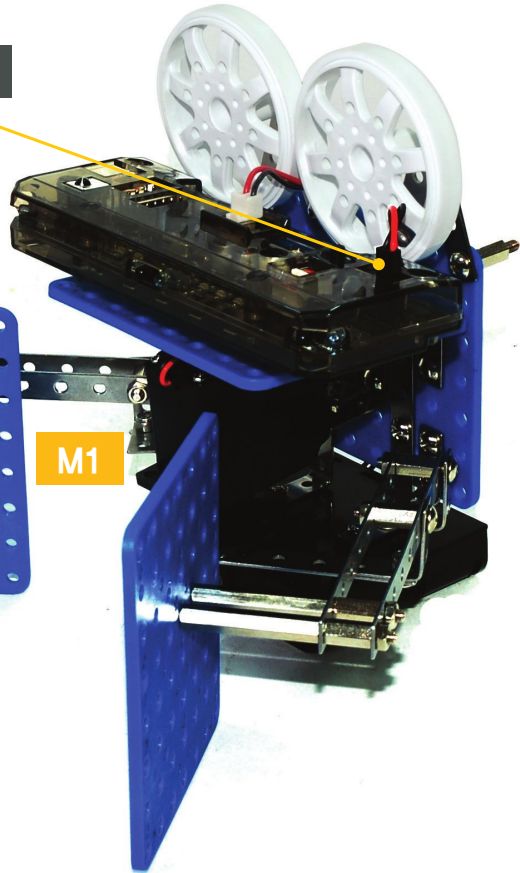
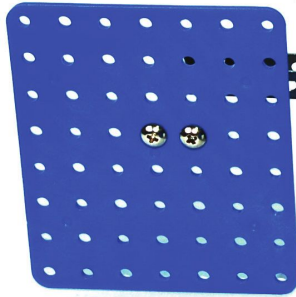

Front view

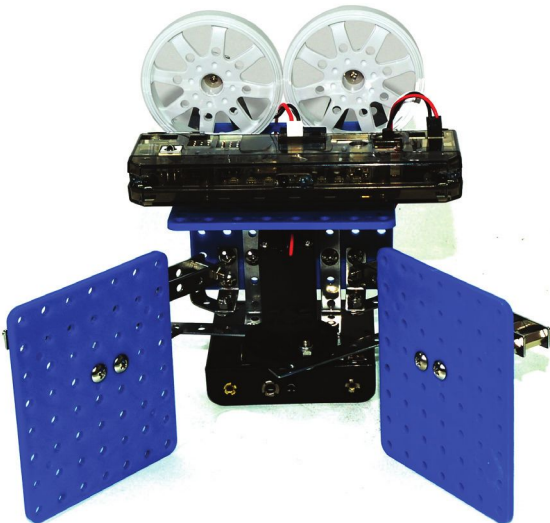

Right view

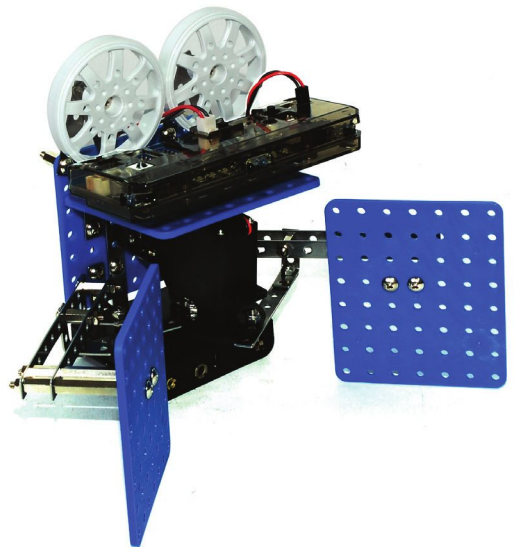

Acting Module



Motion Capture Robot uses program mode 9 to operate.

Before

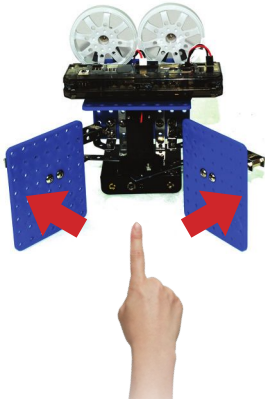

Place your hand between the robot's hands.

After

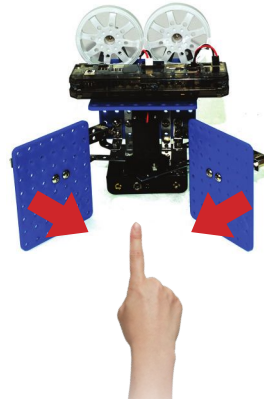

Put your hand near the center sensor.

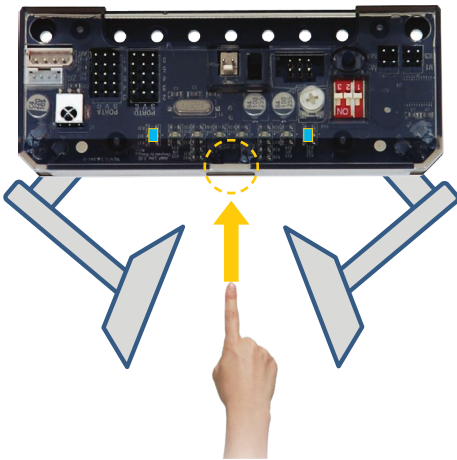

The robot waits with its hands opened.

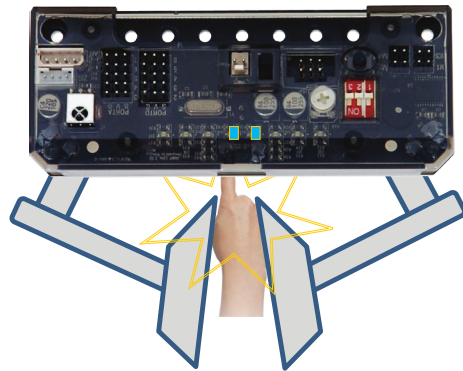

When the center sensor detects your hand, it will catch your hand.

Play the Game!



1. Two players become a team, and play the game.
2. Select program mode 5 on the smart board.
3. Two players do rock paper scissors first, and a lost player needs to put his/her hand between the robot's hands, and take his/her hand out from the robot. If he/she lost the rock paper scissors by scissors, she/he needs to put his/her hand between the robot's hands 5 times. If she/he lost the game by rock, she/he needs to do it 7 times, and by paper, do it 10 times.
4. If the sensor does not detect the player's hand, it does not count.
5. If the robot's hands catch the player's hand, she/he loses the game. There will be a penalty for the lost player.
6. If the player takes out his/her hand so quickly that his/her hand does not get caught by the robot, then the player does not get the penalty.

